

Modular Cooking Range Line

Electric rethermalizer 1x40lt, 240V

ITEM # _____

MODEL # _____

NAME # _____

SIS # _____

AIA # _____

391999 (E9PCPDRMC0)

 Electric Freestanding
 Rethermalizer, 1 Well - 40
 litres - 240 V

Short Form Specification

Item No.

Electric single-phase freestanding re-thermalizer unit for soups. 40 liters water well capacity, able to fit and re-thermalize 10 soup bags simultaneously in 60 minutes, thus optimizing energy and water consumption. Unit designed to operate using only electric power water supply and water discharge, no other connections required. The 40 liter tank is pressed in 316-L type stainless steel to protect against corrosion. Exterior panels in stainless steel. Worktop in 1,5mm stainless steel. Easy to use electronic control panel with LED display allows to choose between two program cycles - default re-therm program and searing program. Infrared heating system located in external base of the well. Safety thermostat prevents the machine from working without water. Well equipped with 2 dedicated AISI 304 stainless steel racks, fitting 5 bags each (10 bags total). Delivered on 200 mm high feet.

Main Features

- Easy to use electronic control panel with LED display showing water temperature and re-therm cycle countdown. An acoustic alarm warns the operator when the cycle is completed.
- Two program cycles available:
 - Default re-therm program: the cycle allows the re-thermalization of minimum 2 and up to a maximum of 10 bags of soup from 5°C to 80°C in 60 minutes (at an ambient temperature of 20°C. Times may vary depending on soup and bag type as well as bag temperature from fridge).
 - Searing program: allows the operator to extend the re-therm cycle for additional 10 minutes, if a higher temperature is required.
- When launching a cycle, if the water is below 75° C the unit will display "PrEh" and the countdown will start once the temperature of 75° C is achieved.
- Well equipped with a dedicated temperature sensor to control the water temperature and 3 additional sensors to manage the water level.
- Overflow sensor detects if the water exceeds the maximum level and automatically activates the drainage pump connected to the overflow pipe.
- Safety thermostat prevents the machine from running without water.
- Automatic water level filling and re-filling.
- Well equipped with 2 dedicated AISI 304 stainless steel racks, able to fit 5 bags each (10 bags totally). The racks have a flexible wall to maintain the correct bag position during the cycle, thus guaranteeing maximum performances.

Construction

- Water basin in 316-L type Stainless steel to avoid corrosion.
- One piece pressed 1.5 mm worktop in stainless steel with smooth, rounded corners.
- Exterior panels in stainless steel with Scotch Brite finish. Back, bottom and front made in stainless steel.
- Stainless Steel removable support located inside the well to support the soup bags.
- Infrared heating system positioned under the external base of the well to ensure elevated performances.
- Safety thermostat automatically switches off the appliance in case of overheating.
- Rear hinged swiveling cover and handle with spring torsion mechanism to allow the cover to remain open during operations.
- Water drain positioned on the back of the appliance with an external flexible pipe to facilitate well discharging.
- Integrated water drain pump to manage draining operations and water overflow.
- Mounted on 200 mm high feet.
- Equipped with 2 meter cable with plug.
- IPx4 water protection.

Optional Accessories

APPROVAL: _____

Front

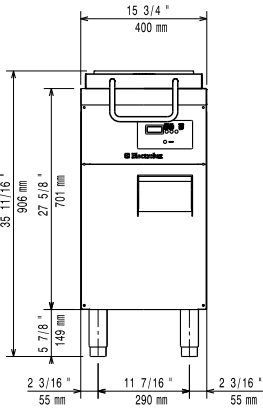

Side

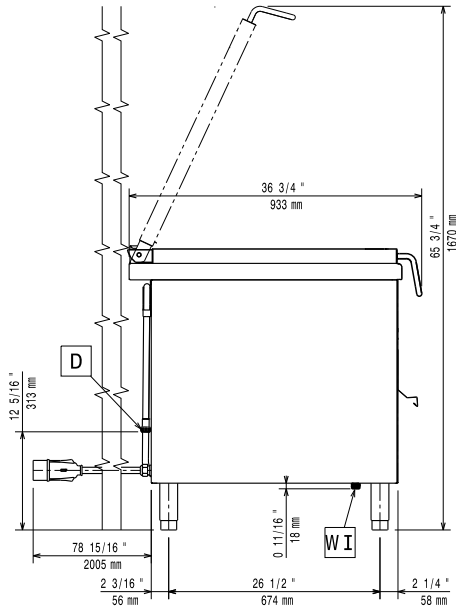

- D = Drain
- EI = Electrical inlet (power)
- EQ = Equipotential screw
- WI = Water inlet

Top

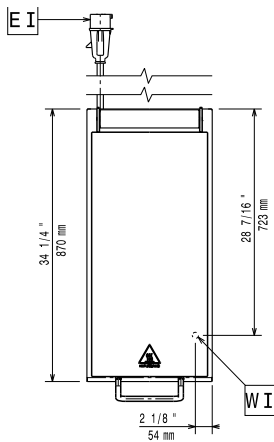

Electric

Supply voltage: 220-240 V/1 ph/50 Hz
Total Watts: 3.5 kW

Water:

Incoming Cold/hot Water
line size: 3/4"
Drain line size: 3/4"

Key Information:

Number of wells: 1
Usable well dimensions
(width): 300 mm
Usable well dimensions
(height): 260 mm
Usable well dimensions
(depth): 510 mm
Well capacity: 22 lt MIN; 40 lt MAX
Thermostat Range: 85 °C MIN; 95 °C MAX
External dimensions,
Width: 400 mm
External dimensions,
Depth: 933 mm
External dimensions,
Height: 850 mm
Shipping weight: 68 kg
Shipping height: 1080 mm
Shipping width: 460 mm
Shipping depth: 1020 mm
Shipping volume: 0.51 m³
Configuration: Free Standing
Approvals: CE;CB;WRAS
Certification group: N9RT